

Basler pio^{veer}



Preliminary

Innovative, Slim Design, Extremely Cost-effective

BASLER 
VISION TECHNOLOGIES

pioneer Series – Are You Looking for a Digital Camera That Combines Speed, High Image Quality, and an Excellent Price/Performance Ratio?

Basler pioneer Family – 8 new Gigabit Ethernet based camera models that are innovative, easy to integrate, have a slim design, and are extremely cost-effective

The Basler pioneer camera family is based on four selected Kodak CCD sensors for exceptional image quality. Equipped with a GigE Vision compliant interface, these cameras take maximum advantage of Kodak sensor technology and can often substitute for more cost-intensive Camera Link cameras and frame grabbers. Because Basler pioneer cameras use the same sensors currently used in existing Camera Link cameras, no optics changes are required.

For more flexibility, this series offers additional software features that can be integrated into the image processing software on a remote computer.

Your benefits from the Basler pioneer family include:

- Resolutions from VGA to 2 megapixels
- 100 meter cable lengths provided by Gigabit Ethernet to give you the highest flexibility
- Free GigE Vision compliant driver package with performance and filter drivers
- Smallest housing in its class with a 29 x 44 mm footprint
- An easy replacement for Camera Link cameras (e.g., no change of lens)
- Cost-effective Gigabit Ethernet interface does not need a frame grabber
- Compliant with the newest vision industry standards including GenICam, GigE Vision, and EMVA 1288
- 100% quality checked and calibrated to give you consistent performance and reliability

Basler pioneer cameras are a perfect fit for a variety of vision applications including semiconductor and component inspection, food inspection, manufacturing quality control, intelligent traffic systems, microscopy and medical imaging, biometrics, and many others.

Software Makes Image Processing Easy

The Basler pioneer family comes with a fully tested package of software that lets you easily evaluate and integrate pioneer cameras. The package can be downloaded from Basler's website.



Using the viewer included in the package, you can capture a single image or capture images continuously. The viewer gives you full access to camera parameters, letting you adjust image quality and control cameras from a remote computer. Using the viewer is a very easy way to integrate a Basler camera into your application.

Basler also offers a complete software development kit (SDK) to ensure maximum flexibility for customer-specific applications.

Outstanding Image Quality

The Basler pioneer family is equipped with four different Kodak CCD sensors with each camera available in mono or color. These sensors were selected to provide outstanding image quality in combination with the Basler pioneer's read-out and processing electronics. For precise imaging results, all Basler pioneer cameras run in progressive scan mode.

Precise Sensor Alignment

In addition to Basler's standard CCT+ automated quality assurance and calibration system, the pioneer camera family will be tested and measured with another production tool. This unique tool is an ultra-high precision sensor alignment device. The device automatically mounts the sensor board on the camera's front module in six degrees of freedom with reference to the optical axis. This ensures a constant depth of focus over the whole sensor and guarantees the best imaging results, even with sensors that have pixels smaller than 5 µm.

Pixel Formats and Preprocessing

For maximum flexibility in color representation, Basler pioneer color cameras feature a variety of pixel formats. YUV 4:2:2 pixel formatting is done inside of the camera and YUV image data can be obtained directly. For individual processing, each pixel can be read out separately as a raw value at 8 or 12 bit depth and can be processed as desired in your remote computer. The pioneer series features brand new pixel formats that intelligently organize 12 bit pixel data inside of the camera to take full advantage of the interface bandwidth.

Gigabit Ethernet (GigE Vision) Drivers

Basler provides its own fully tested Gigabit Ethernet drivers for the Basler pioneer camera family. These drivers will be compatible with the GigE Vision standard and optimized for the Basler pioneer family.

To give you maximum flexibility, Basler provides two different drivers:

Filter Driver: The filter driver quickly separates incoming packets that contain image data from other traffic on the network and makes the data available to an application running on the computer. This driver can be easily used with common Gigabit Ethernet network cards or with Gigabit Ethernet ports that are part of the computer's motherboard.

Performance Driver: By using the performance driver, even demanding applications with multiple cameras, high data rates, or very strict real-time requirements can be supported. When the performance driver is used in combination with a dedicated network interface card (Intel), the load on the host computer's CPU is significantly reduced. This driver is based on dedicated Intel network interface cards and can be used to get maximum performance from your application.

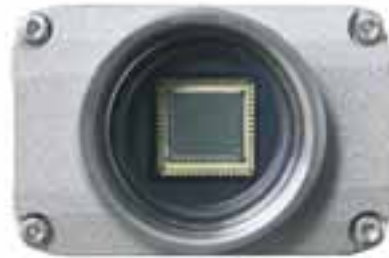

Specifications

Basler pioneer	piA640-210gm/gc	piA1000-48gm/gc	piA1600-35gm/gc	piA1900-32gm/gc
Camera				
Sensor Size (H x V pixels)	648 x 488	1004 x 1004	1608 x 1208	1920 x 1084
Sensor Type	Kodak KAI-0340	Kodak KAI-1020	Kodak KAI-2020	Kodak KAI-2093
Sensor Read Out	Progressive Scan CCD			
Pixel Size (in μm)	7.4 x 7.4	7.4 x 7.4	7.4 x 7.4	7.4 x 7.4
Max. Frame Rate (at full resolution)	210	48	35	32
Mono/Color	yes/yes	yes/yes	yes/yes	yes/yes
Data Output Type (Interface)	Gigabit Ethernet (GigE Vision compliant)			
Pixel Data Formats	Mono 8: 8 bits/pixel Mono 16: 12 bits/pixel YUV 4:2:2: 16 bits/pixel average Raw 8: 8 bits/pixel (R,G or B) Raw 16: 12 bits/pixel (R,G or B) and packed formats			
Synchronization	via external trigger, via software trigger, or free run			
Exposure Control	programmable via the camera API			
Mechanical / Electrical				
Power Requirements	12-24 VDC; via Hirose 12-pin connector (max. 10 meter cable lengths)			
I/O Ports	2 opto-isolated input ports, 4 opto-isolated output ports			
Lens Mount	C-Mount			
Typical Power Consumption (at 12 V)	< 5.5 W			
Housing Size (L x W x H)	86.7 mm x 44 mm x 29 mm			
Weight (typical)	~ 200 g			
Conformity	CE, FCC			
Software Environment				
Software Driver	filter driver and performance driver (Basler pylon driver package)			
GenlCam Compliant	yes	yes	yes	yes

Specifications are subject to change without prior notice.

Dimensions (in mm)

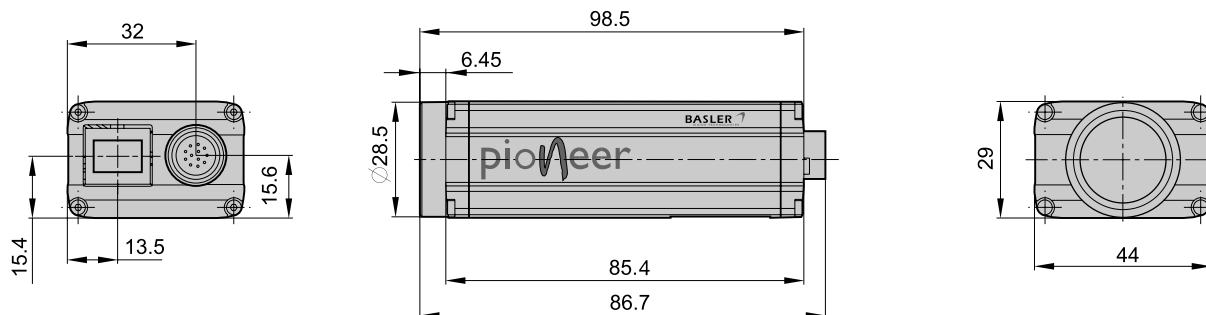

Innovative Technologies in the Basler pioneer Family

100 Meter Cable Lengths – High Bandwidth – No Frame Grabber



Basler's pioneer family has a Gigabit Ethernet (GigE) interface compliant with the GigE Vision standard.

GigE has become a synonym for the new interface technology used in machine vision systems and in

related industries like intelligent traffic systems and medical imaging. High bandwidth, long cable lengths, and wide usage in the consumer and industrial markets are the key elements that make GigE attractive for your application.

Because Gigabit Ethernet breaks the bandwidth barrier that was set by FireWire, switching from Camera Link to Gigabit Ethernet is now attractive for you. Another clear advantage of the pioneer family is a quantifiable reduction in the cost of a total vision solution because a frame grabber is no longer required. No less important is the 100 meter cable lengths offered by Gigabit Ethernet. These expanded capabilities open exciting new possibilities for vision system design and break through existing limitations to reach a new level that is especially beneficial for factory floor applications.

Unified API – Simple Programming – Interface Independent



Basler pioneer cameras will be GenCam compliant

and will include an IEEE 1394 driver, GigE filter driver, and GigE performance driver. The pioneer software will also implement a newly designed image viewer.

The core of GenCam is a description of the camera's properties in an XML descriptor file. Using this file, a translator can directly generate either a C++ application programming interface (API) called GenAPI or the elements of a graphical user interface (GUI). This lets the user easily identify the camera type, as well as the features and functions available on the camera and the parameters associated with each camera function. Future extensions of GenCam will also provide mechanisms for grabbing and streaming images from the camera. The proposed GigE Vision standard stipulates that cameras must provide the XML descriptor file. A descriptor file for IEEE 1394 compliant cameras will be available as well.

Sensitivity Measurement – Reliable Camera Comparison



Basler-VC is leading the effort to standardize image quality and sensitivity measurement for machine vision cameras and sensors. All measurements done by Basler will

be in 100% compliance with the new European Machine Vision Association EMVA 1288 standard. Because it describes a unified

method to measure, compute, and present the specification parameters for cameras and image sensors used in machine vision applications, Basler is giving the EMVA 1288 standard our strongest support.

The pioneer family will be characterized and measured to provide information about the quality and sensitivity of our products.

What Makes Basler Camera Quality So Special?



Basler Camera Test Tool

To ensure consistently high product quality, we employ several quality inspection procedures during manufacturing. This list describes three of the most essential actions we take to meet your highest requirements.

- The back focal length on each camera is carefully measured and adjusted. This guarantees an optimum distance between the lens flange and the sensor and ensures compliance with optics standards.
- Our advanced Camera Test Tool (CTT+), the first fully-automated inspection system for digital cameras, checks all of the significant quality aspects of each camera we produce. The CTT+ is a unique combination of optics, hardware, and

software that can be quickly and efficiently used to calibrate a camera and to measure its performance against a set of standards. For defined sets of conditions, an automated software program examines the camera's output, makes any calibration adjustments necessary, and compares the output to a strictly defined set of performance criteria.

- As a final check, our cameras must pass a stress test. Each camera is tested over the entire temperature range specified in our documentation. By doing this, we can identify and remove temperature sensitive weak spots in the camera. Consistent image quality in conditions with quickly changing temperatures is thereby guaranteed.

Basler customers get a 100% tested camera, all of the benefits that go along with 100% testing, and a much higher level of satisfaction. This is a definite win-win situation.



www.basler-vc.com

Germany, Headquarters

Fon +49 4102 463 500
 Fax +49 4102 463 599
vc.sales.europe@baslerweb.com

USA

Fon +1 610 280 0171
 Fax +1 610 280 7608
vc.sales.usa@baslerweb.com

Singapore

Fon +65 6425 0472
 Fax +65 6425 0473
vc.sales.asia@baslerweb.com